

ISM7100-3GF-2D-2C

10-Port Layer 2 Gigabit Managed Embedded Switch Module With 4 Fieldbus Ports



- Support 3 1000M Ethernet ports and 7 100M Ethernet ports, 2 TTL UART and 2 TTL CAN ports, providing flexible networking options
- Support ring network redundancy protocols such as MW-Ringv1/v2, ERPS, STP/RSTP, to improve network reliability
- Support serial port terminal equipment networking, can convert UDP, TCP, Modbus, HTTPD, WebSocket and other protocols, and support virtual serial port
- Support CAN terminal equipment networking and realize transparent transmission between CAN bus and Ethernet (UDP/TCP)
- Compact structure and small size, convenient for installation, maintenance and PCBA
- Support DC 3.3V power input
- Support working reliably in harsh industrial environments ranging from -40°C to +75°C



Product Description

ISM7100-3GF-2D-2C is a Layer 2 Gigabit managed embedded switch module. It provides 3 1000M Ethernet ports and 7 100M Ethernet ports with fiber port or copper port optional, and also provides 2 TTL UART and 2 TTL CAN to expand RS232/485 serial port and CAN bus port. The switch adopts a store-and-forward mechanism and has powerful bandwidth processing capabilities to automatically troubleshoot data packet errors, reduce transmission

failures, and ensure stable, reliable, and efficient data transmission. The hardware adopts low power consumption, wide temperature, modular design, compact structure and small size. It is easy to install and maintain, and the board can be flexibly made to customize the interface connection method; selected industrial-grade components, $-40^{\circ}\text{C}\sim+75^{\circ}\text{C}$ wide temperature operation, embedded installation method, can adapt to various harsh working environments, and the communication performance is stable.

ISM7100-3GF-2D-2C supports a range of features and network protocols, such as MW-Ringv1/v2, ERPS, STP/RSTP, VLAN, LACP, LLDP, SNMPv1/v2c/v3, QoS, 802.1X, IGMP Snooping, WEB access control, static aggregation, port mirroring, static multicast MAC address binding, network diagnosis, email log, alarm, SNTP, system log and system online upgrade, etc., which can improve the performance, reliability and security of the network and meet the needs of requirements of various complex networks. It supports multiple network working modes such as UDP, UDP Multicast, TCP Client/Server, Modbus RTU Master/Slave, Modbus ASCII Master/Slave, RealCOM_MCP/CCP/MW, Pair Connection Master/Slave, HTTPD Client, WebSocket Client, etc., to achieve serial port to Ethernet or Modbus TCP protocol conversion. And supports network working modes such as UDP, TCP Client/Server, UDP multicast, etc., to achieve CAN terminal device networking. This product meets the requirements of complex networks and harsh industrial environments through strict testing of functions, high and low temperatures, safety regulations and EMC. It can be widely used in fields such as comprehensive energy, smart cities, rail transit, intelligent transportation, smart factories, and industrial automation.



Features and Benefits

- Support rate limits for broadcast, multicast, and unknown unicast messages, detect broadcast and multicast packet storms, and prevent broadcast storms
- Support serial port and CAN terminal device networking, extending transmission distance, and achieving centralized network management
- Support conversion between Modbus RTU/ASCII and Modbus TCP protocols, and support Modbus RTU/ASCII Over TCP transparent transmission
- Support multiple sub-packaging mechanisms to convert serial port/CAN data into Ethernet data packets to meet the real-time needs of different networks
- Support Modbus ID mapping, mapping the real ID of the Modbus slave to a virtual ID for data communication to avoid duplication of slave IDs
- Support QoS quality of service, allowing voice, video and important data to be transmitted preferentially in network equipment to solve network congestion
- Support 802.1Q VLAN and provides Access, Trunk, and Hybrid interfaces to easily divide multiple broadcast domains and enhance network security.
- Support IGMP Snooping and establishes a Layer 2 multicast forwarding table to reduce the broadcast of multicast data in the network and save network resources.
- Support LLDP link layer discovery protocol, obtains LLDP neighbor device information, and monitors link status to facilitate topology management and fault location.
- Support ERPS Ethernet multi-ring protection technology, provides multi-ring networking, performs link backup, achieves rapid convergence, and improves network stability
- Support link static aggregation, which can increase transmission bandwidth and improve link reliability
- Support RSTP (Rapid Spanning Tree Protocol) compatible with STP (Spanning Tree Protocol) to eliminate network loops and enhance network reliability
- Support WEB control, HTTP, HTTPS protocol access control, login IP address restriction
- Support 802.1X port authentication, authenticates access users, and provides local and RADIUS login authentication.
- Support SNMPv1/v2c/v3 centralized management and SNMPv1/v2c/v3 TRAP information
- Support alarm function, including alarms for external power supply, network storm, port disconnection
- Support port statistics, count different types of data frames sent and received, and monitor port traffic
- Support port mirroring, which can collect port inlet and outlet data for network detection and fault management.
- Support system log information recording, downloading and classification, and can be output to WEB pages, log hosts and consoles for display



Specification

Software	
Switching	Support port configuration, rate configuration, storm detection, port aggregation, LACP and port statistics Support 802.1Q VLAN Support MAC address aging and static MAC address binding
Serial Port	Support UDP, UDP Multicast, TCP Client, TCP Server, Modbus RTU Master, Modbus RTU Slave, Modbus ASCII Master, Modbus ASCII Slave, RealCOM_MCP, RealCOM_CCP, RealCOM_MW, Pair Connection Master, Pair Connection Slave, Httpd Client, WebSocket Client and other network work model Support packet length, packet interval, network connection information Support Modbus slave address mapping, Modbus pre-reading, Modbus Over TCP Support heartbeat packet, registration packet, frame header and tail mode, RFC2217 function
CAN	Support UDP, TCP Client, TCP Server, UDP multicast and other network working modes Support packet frame number, packet interval, CAN ID filtering, network connection information
Redundancy	Support MW-Ringv1/v2 proprietary ring network technology Support ERPS Support RSTP (Rapid Spanning Tree Protocol) and is compatible with STP (Spanning Tree Protocol)
Multicast	Support static multicast MAC address binding Support IGMP Snooping
Security Management	Support WEB access control Support 802.1X port authentication Support the relay alarm, Email log
Management and Maintenance	Support QoS, SNMP v1/v2c/v3, SNMPv1/v2c/v3 TRAP, LLDP Support port mirroring, Ping Support user rights management, system logs, local/network time synchronization Support online restart, factory reset, system upgrade, configuration file upload/download Support MW-NMPv2, MixView, MaxView management
Switch Capability	
Processing Type	Store and Forward
Backplane Bandwidth	7.6Gbps
Buffer Size	1MBit
MAC Table Size	8K



Specification

Interface	
1000M Ethernet Port	3*1000M Ethernet ports, expandable to 10/100/1000Base-T(X) copper port or 1000Base-FX fiber port
100M Ethernet Port	7*100M Ethernet ports, expandable to 10/100Base-T(X) copper port or 100Base-FX fiber port
TTL UART	Number of interfaces: 2 Interface type: 3.3V TTL UART, can be connected to an external serial port chip to expand the RS232/485 serial port Baud rate: 300bps-460800bps Data bits: 7bit, 8bit Stop bit: 1bit, 2bit Check digit: no check, odd check, even check
TTL CAN	Quantity: 2 CAN bus ports Type: 3.3V TTL CAN port, can be connected to an external CAN transceiver chip to expand the CAN bus port Baud rate: 5kbps-1000kbps
Alarm Interface	1*alarm output and 2*alarm input
CONSOLE	1 TTL UART for device debugging
Power Supply	
Input Voltage	DC 3.3V(±3%)
Power Consumption	<3W@DC3.3V
Physical Characteristics	
Dimensions	70×50×11.6 mm
Installations	Embedded installation
Weight	About 42g
Working Environment	
Operating Temp	-40℃~+75℃
Storage Temp	-40℃~+85℃
Relative Humidity	5%~95% (non-condensing)



Dimensions

Unit: mm

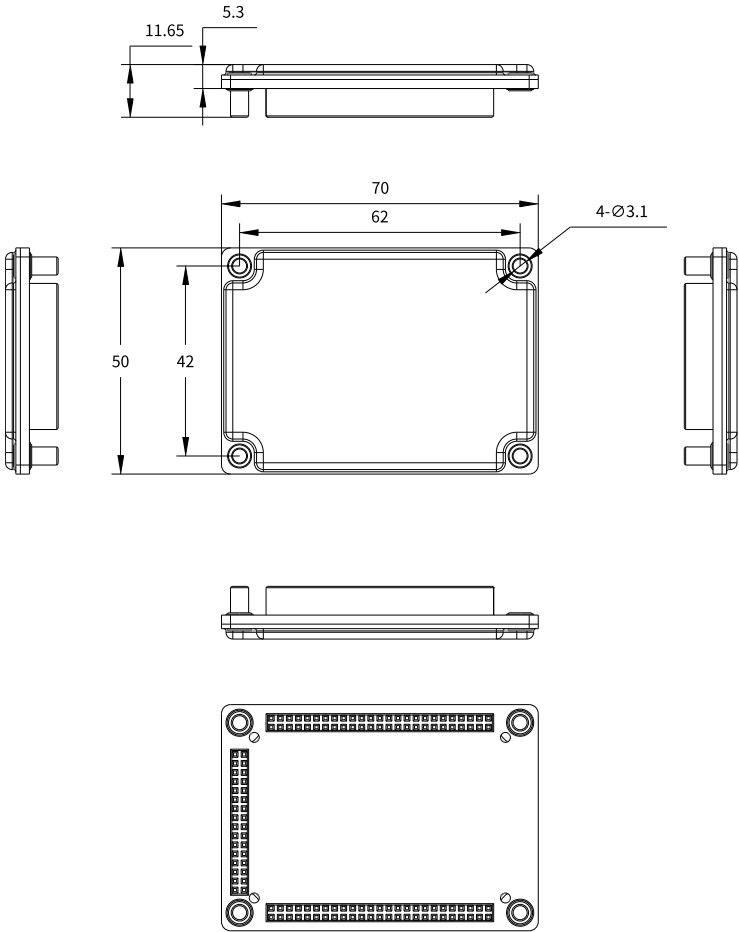



Ordering Information

Standard Model	1000M Ethernet Port	100M Ethernet Port	UART	CAN	Input Voltage
ISM7100-3GF-2D-2C	3	7	2	2	DC 3.3V



Contact Us

Wuhan Maiwe Communication Co., Ltd

Address: No.52 Liufang Avenue, East lake High-tech Development Zone, Wuhan, China.

Tel: 027-87170217

Mail: enquiry@maiwe.com

Official site: www.maiwe.com

Copyright © Maiwe Communication All rights reserved