

# MIAP7200

## Industrial DIN-Rail Wi-Fi 6 Wireless AP



- 1\*Gigabit WAN/LAN port (fiber/copper port, copper port supports PoE power supply), 4\*Gigabit LAN ports (copper port) and 2\*2.4GHz/5GHz antenna interfaces
- Support Wi-Fi 6 dual-band WLAN wireless LAN, support OFDMA+MU-MIMO technology
- Support routing, AP, relay, bridge and client working modes
- Support WDS wireless and WISP universal bridging to expand and extend wireless signals
- Support advanced settings such as short protection time interval, segmentation threshold, RTS threshold, pure G mode, pure 11N mode, etc.
- Support firewall and service functions such as port forwarding, IP/MAC speed limiting/filtering, DMZ, QoS, intranet penetration, DDNS, VPN, SNMP, LLDP, etc
- High-strength aluminum alloy casing, IP40 protection level, fanless design
- Work in harsh industrial environments of -40°C~+70°C



Product Description

The MIAP7200 is a 5-port Gigabit DIN-Rail dual-band Wi-Fi6 industrial wireless AP designed and developed specifically for industrial communication network applications. It provides 2\*2.4GHz/5GHz antenna interfaces and 1\*Gigabit WAN/LAN port and 4\*Gigabit LAN ports, supporting 2\*DC12~60V power input, and support power redundancy; the copper port supports 802.3af/at standard PoE. It receives power and adopts standard DIN rail installation method to meet the needs of various network sites.

The product supports WEB configuration of a variety of network management functions, such as routing/AP/relay/bridging/client mode, universal/WDS bridging, fast roaming, AC control, dynamic/static/PPPoE dial-up networking, IP address conflict detection, DHCP server, IP/MAC binding, radio frequency settings, black and white list, static routing, network diagnosis, firewall, intranet penetration, DDNS, VPN, SNMP, LLDP, NTP, etc.; the system provides user management with different permissions and support local/remote log management. The hardware adopts high-standard industrial protection design, with industrial-grade components and high-strength aluminum alloy casing, which is sturdy and durable; it is featured with low power consumption, fanless casing heat dissipation, supports 40°C~+70°C operating temperature, and passes strict safety regulations and EMC testing meet the application requirements of harsh industrial environments. The industrial AP can be widely used in industrial automation, integrated energy, smart cities, smart transportation, smart mines, smart factories and other field.



## Features and Benefits

- Support OFDMA+MU-MIMO technology, providing multi-concurrency in frequency domain and physical space, improving multi-user high-density access
- Support Wi-Fi 6 dual-band WLAN wireless LAN, 2.4G theoretical maximum rate 574Mbps, 5G supports 160MHz bandwidth with the theoretical maximum rate of 2402 Mbps
- Support routing mode and can connect to the external network through dynamic/static/PPPoE dial-up methods to realize wired and wireless terminal networking
- Support AP mode, which can convert the wired network into a wireless network, allowing wireless terminals to access the wired network, and the AC is controllable
- Support relay mode, which can amplify the upper-level wireless network and convert it into wired and wireless networks to achieve wired and wireless terminal access
- Support bridge mode, which can convert wireless networks into wired and wireless networks to achieve wired and wireless terminal access
- Support client mode, which can convert the wireless network into a wired network and enable wired terminals to access the wireless network
- Support DHCP server to centrally dynamically manage and configure user IP addresses
- Support DHCP access device management, binding client IP and MAC address to avoid IP address changes or conflicts
- Support multiple country code switching, suitable for channels in different regions
- Support 2.4G+5G frequency bands, transmit power adjustment, user number limit, SSID hiding, user isolation, WDS bridging, etc.
- Support WPA/WAP2 and WAP3 encryption methods
- Support wireless user management, black/white list can filter wireless users, prohibit/allow designated wireless users to access
- Support static routing, which can accurately control network routing selection, improve network performance, and ensure network bandwidth.
- Support IPv4/IPv6 Ping, IPv4/IPv6 Traceroute, Nslookup, and packet capture for network diagnosis or fault analysis
- Support SYN-flood defense, port forwarding, IP/MAC/domain name filtering, iptables custom rules, DMZ, UPnP and other firewall functions
- Support NTP client and server functions, can perform clock synchronization or provide clock source
- Log information records multiple levels of kernel, application and network information, and supports local downloading, scheduled saving, and remote monitoring
- Support Peanut Shell intranet penetration, and can use Peanut Shell dynamic domain name to remotely log in and manage equipment
- Support dynamic DNS function, and can remotely log in and manage the device through the specified domain name
- Support VPN client and server to build a private network
- Support SNMPv1/v2c and SNMP Trap. Information query, information modification and troubleshooting can

be carried out through MIB to achieve centralized management

- Support LLDP to obtain LLDP neighbor device information, and monitor link status to facilitate topology management and fault location

## Specification

Software	
Network Management Function	<p>Support traffic statistics, operating status, network status, local address and other status information or wireless information</p> <p>Support routing mode, AP mode, relay mode, bridge mode, client mode</p> <p>Support static address, DHCP, PPPoE external network connection</p> <p>Support DHCP server, IP/MAC binding, wireless user black and white list</p> <p>Support IP address conflict detection</p> <p>Support static routing</p> <p>Support peanut shell intranet penetration, dynamic DNS, SNMP, LLDP</p> <p>Support PPTP/L2TP/GRE/TUN/TAP protocol VPN client</p> <p>Support PPTP/L2TP/IPSec protocol VPN server</p>
Firewall	<p>Support SYN-flood defense, IP dynamic camouflage, MSS clamping, inbound/outbound data control</p> <p>Support WAN/LAN port TCP/UDP port mapping</p> <p>Support IP/MAC/domain name filtering, iptables, DMZ, UPnP</p>
System Management	<p>Support IPv4/IPv6 Ping, IPv4/IPv6 Traceroute, Nslookup, and capture network packets</p> <p>Support time zone, NTP client/server, Crontab, remote/local log</p> <p>Support user permission management, SSH</p> <p>Support online restart, scheduled restart, configuration backup/restore, firmware flash, and factory reset</p>
Wi-Fi RF Parameters	
Wireless Standards	<p>Wi-Fi 6 6th generation wireless network technology</p> <p>2.4GHz 802.11b/g/n/ax</p> <p>5GHz 802.11a/n/ac/ax</p>
Modulation	<p>DBPSK, DQPSK, CCK, OFDM, 16-QAM, 64-QAM, 256-QAM, 1024-QAM</p>
Maximum Transfer Rate (Theoretical value)	<p>2.4GHz: 574Mbps</p> <p>5GHz: 2402Mbps</p>

Maximum Transmit Power	<p>2.4GHz:</p> <ul style="list-style-type: none"> <li>+17dBm HE40 at -47dB DEVM</li> <li>+22dBm HE40 at -43dB DEVM</li> <li>+24.5dBm MCS9 HT40 at -35dB DEVM</li> <li>+26dBm MCS7 HT20/40 at -30dB DEVM</li> <li>+28dBm MCS0 HT20</li> </ul> <p>5GHz:</p> <ul style="list-style-type: none"> <li>+19dBm MCS11 HE160 at -43dB DEVM</li> <li>+16dBm MCS11 HE80 at -47dB DEVM</li> <li>+18dBm MCS11 HE80 at -43dB DEVM</li> <li>+23dBm MCS9 VHT80 at -35dB DEVM</li> <li>+24dBm MCS7 HT20/40 at -30dB DEVM</li> <li>+26dBm MCS0 HT20</li> </ul>	
Receiving Sensitivity	<p>2.4GHz:</p> <ul style="list-style-type: none"> <li>-69.0dBm (VHT40/ MCS9/ 2SS)</li> <li>-63.0dBm (VHT40/ MCS11/ 2SS)</li> <li>-68.5dBm (HT40/ MCS9/ 2SS)</li> <li>-63.0dBm (HE40/ MCS11/ 2SS)</li> </ul> <p>5GHz:</p> <ul style="list-style-type: none"> <li>-64.5dBm (VHT80/ MCS9/ 2SS)</li> <li>-59.0dBm (VHT80/ MCS11/ 2SS)</li> <li>-64.0dBm (HE80/ MCS9/ 2SS)</li> <li>-58.0dBm (HE80/ MCS11/ 2SS)</li> <li>-58dBm (HE160/ MCS9/ 2SS)</li> </ul>	
<b>Interface</b>	<b>MIAP7200-2N25-GF-4GT</b>	<b>MIAP7200-2N25-5GT</b>
1000M WAN	1*1000Base-X Gigabit WAN/LAN port, SFP port	1*100/1000Base-T(X) auto-sensing WAN/LAN RJ45 ports, full/half duplex, auto MDI/MDI-X; supports standard PoE power supply, compliant with IEEE802.3af/at standard
1000M LAN	4*10/100/1000Base-T(X) auto-sensing LAN ports, RJ45 connector, full/half duplex, auto MDI/MDI-X	
Antenna Connector	2*2.4GHz/5GHz antenna interface, using SMA-K (external thread and internal hole)	
Console	1 console port, RJ45 port with RS232 signal, used for equipment debugging	
Button	Restart or factory reset with one click	
Status LED	Power indicator, operation indicator, WiFi indicator, interface indicator, Bridge indicator, PoE indicator (5GT model), Ethernet interface indicator.	
<b>Power Supply</b>	<b>MIAP7200-2N25-GF-4GT</b>	<b>MIAP7200-2N25-5GT</b>

Input Voltage	DC12~60V, dual power supply redundancy	DC12~60V, dual power supply redundancy (The WAN port supports standard PoE power reception. Comply with IEEE802.3af/at standard)
Power Consumption	< 14.5W@DC12V	< 12.5W@DC12V
Connection Method	5-position 5.08mm pitch terminal block	
Protection	No polarity	
<b>Physical Characteristics</b>		
Dimensions	140×54×110 mm (not containing DIN rail mounting clip)	
Installation Method	Easy installation on 35mm DIN rails	
Chassis Protection	IP40	
Weight	About 0.4kg	
<b>Working Environment</b>		
Operating Temp	-40℃~+70℃	
Storage Temp	-40℃~+85℃	
Relative Humidity	5%~95% (non-condensing)	
<b>Industry Standard</b>		
EMC	IEC 61000-4-2 (ESD): Level 4 IEC 61000-4-5 (Surge): Level ※The network port supports 6kV lightning protection IEC 61000-4-4 (EFT): Level 4	
Certification	CE, FC, RoHS	



## Dimensions

Unit: mm

MIAP7200-2N25-GF-4GT

MIAP7200-2N25-5GT

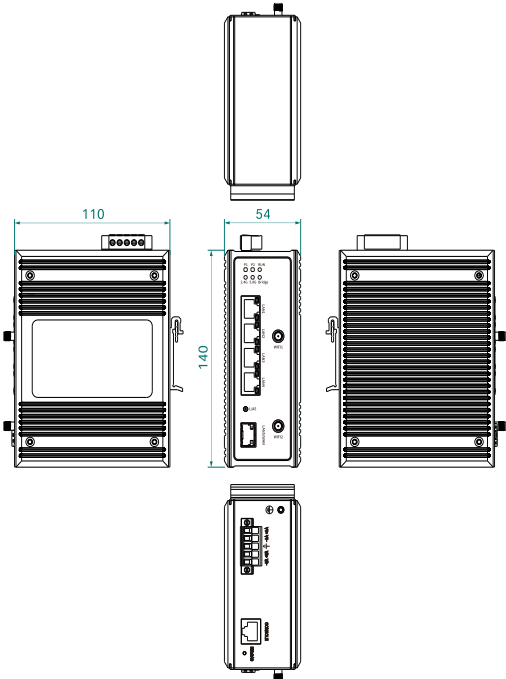
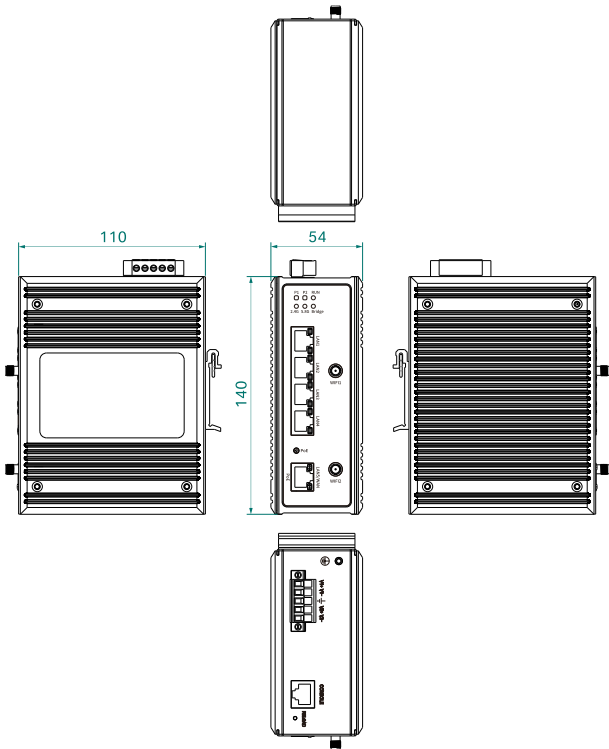



## Ordering Information

Standard Model	1G Fiber Port	1G Copper Port	2.4GHz/5GHz Antenna Interface	Input Voltage
MIAP7200-2N25-GF-4GT	1	4	2	DC12~60V
MIAP7200-2N25-5GT	/	5	2	DC12~60V



## Contact Us

### Wuhan Maiwe Communication Co., Ltd

Address: No.52 Liufang Avenue, East lake High-tech Development Zone, Wuhan, China.

Tel: 027-87170217

Mail: enquiry@maiwe.com

Official site: www.maiwe.com

Copyright © Maiwe Communication All rights reserved