

Industrial Ethernet Switch

User manual

MIGE2206G-2GF-4GT

MIGE2208G-8GT



1 Packing list

The package of this switch contains the following items. If any item is found to be missing or damaged, please contact the agent or the customer service center of Maiwe for assistant

Items	Quantity	Remarks
Industrial Ethernet Switch	1PCS	
Power cord	1PCS	AD220 model only
User Manual	1PCS	

2 Product description

The switch is a full Gigabit unmanaged industrial managed din-rail industrial Ethernet switch. MIEN3206G-2GF-4GT provides 6 Gigabit Ethernet ports (2 Gigabit SFP ports and 4 Gigabit copper ports). MIEN3208G-8GT provides 8 Gigabit Ethernet ports (8 Gigabit copper ports).



MIGE2206G-2GF-4GT

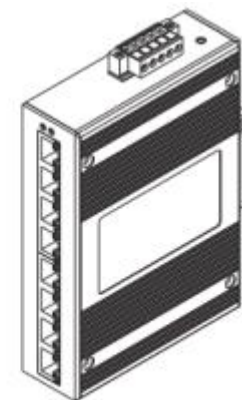

MIGE2208G-8GT

3 Interface description

Unit:mm Take MIGE2206G-2GF-4GF as example

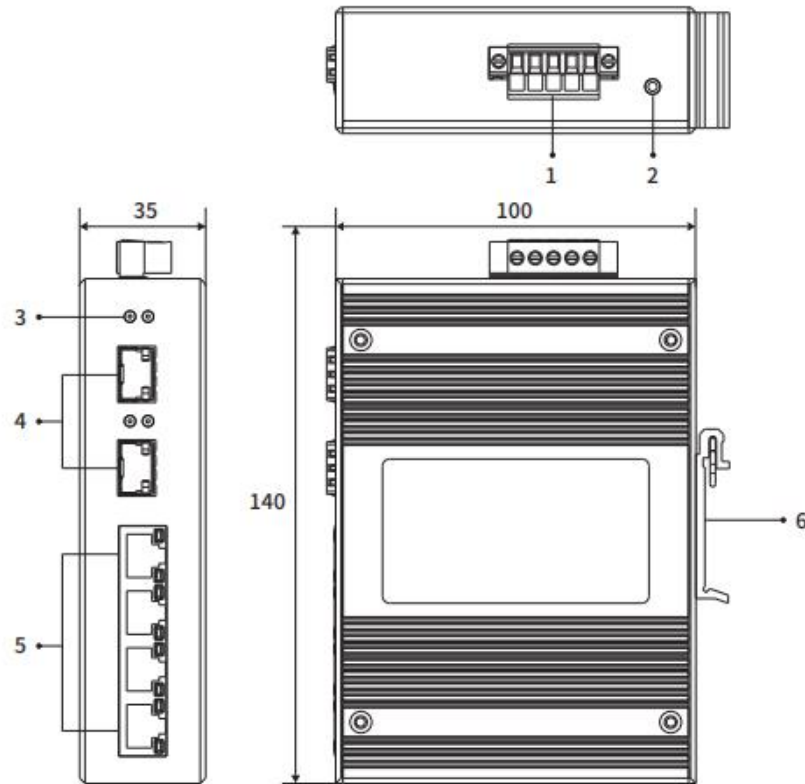

1.Power input terminal	4.Gigabit SFP ports
2. Ground screw	5. Gigabit RJ45 ports
3.Indicator light	6.Din rail kit

The indicator description of the switch is shown in the following table.

Indicator lights	Status	Definition
System status LED		
PWR	On	Power is connected and operating normally
	Off	The power is unconnected or the system is abnormal
RUN	Blinking	System operates normal
	Off	System operates abnormal
Fiber Status LED		
L/A1/G1	On	The port has established a valid network connection
	Blinking	The port has network activity
	Off	The port has not established a valid network connection
Ethernet RJ45 Status LED		
Each Ethernet RJ45 port has two indicator lights,The yellow light is the port rate indicator, and the green is the port		
10/100/1000M (Yellow)	On	1000M work status (1000Base-TX)
	Off	10M/100Mwork statues (10Base-T or 100 Base-TX)
LINK/ACT (Green)	On	The port has established a valid network connection
	Blinking	The port has network activity
	Off	The port has not established a valid network connection

4 Hardware installation

⚠ Installation Precautions

To prevent equipment damage or personal injury caused by improper use, observe the following precautions:

- During the installation process, you need to wear anti-static gloves or anti-static shoes, and power-off the switch.
- Please make sure that the input voltage is within the input voltage range marked on the switch.
- The transmission distance has a certain relationship with the connected wire. It is recommended to use a standard Cat5e/6 network cable.
- The equipment must be grounded for lightning protection, otherwise the protection level of the equipment will be greatly reduced; please use a wire of No. 20 or more to connect the grounding terminal to the ground.
- The power line, ground line and signal line are laid out separately and the distance is not less than 5cm.

Device installation

- Tilt the switch upwards so that the upper end of the buckle is fastened to the upper end of the DIN rail.
- The lower end of the back buckle is buckled into the DIN rail.

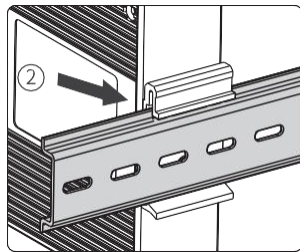
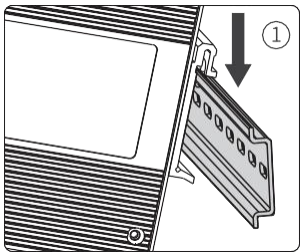

➤ Network cables connection

Device connection

Connect the optical fiber and network cable to the port in the correct

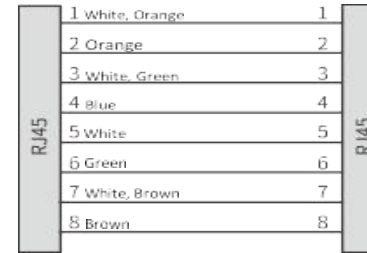
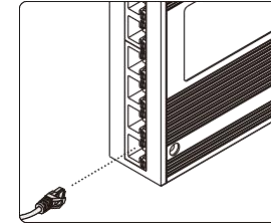

Category5 direct connection

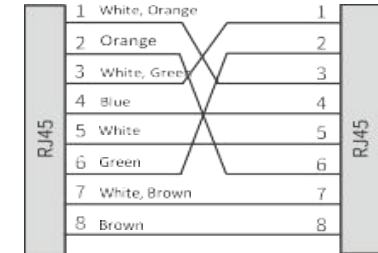

Category5 crossover connection

⚠ Warning

1. Signals were transmitted by laser through optical fiber. The laser meets the requirement of class I, no harm with normal operation. Do not look directly into the fiberport and the end of the optical fiber terminator.
2. Dust plugs need to be installed when optical connectors and optical modules are not in use. Dust caps need to be installed when optical fibers are not in use.
3. The bending radius of optical fiber should be greater than 20 times the diameter of the optical fiber. In general, the bending radius should be equal to or greater than 40mm.

➤ Power input

Before connecting the power cord, make sure that the ground is connected. Do not connect the power cord to the power terminal of the device according to the definition.

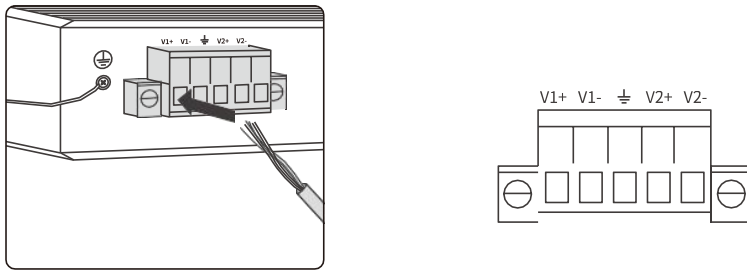

💡 Notes

1. When using a switch, the voltage can only be input from V1+ and V1-, V1+ connects to live wire L, and V1- to neutral wire N. Do not connect from V2+, V2-; pay attention to safety and prevent electric shock.
2. Power-on operation: First connect the power cord to the power terminal of the device according to the definition shown in the figure above, and then power on.
3. Power-off operation: first unplug the power plug, and then remove the power cord.

5 Specifications

	MIGE2206G-2GF-4GT	MIGE2208G-8GT
Switch performance		
Bandwidth	14G	16G
Cache size	2Mbit	1.5Mbit
MAC table size	2K	4K
Interface		
Gigabit SFP port	2x1000Base-X	/
	SFP slot	
Gigabit RJ45 port	4* 10/100/1000MBase-TX RJ45 ports	8* 10/100/1000MBase-TX RJ45 ports
	Full duplex/half duplex self-adaptation, support MDI/MDI-X self-adaptation	
Power		
Power consumption	3.5W@24V (Max)	2.5W@24V (Max)
DC input	DC9-60V	DC9-60V optional, support dual power supply, and reverse connection protection.
AC input	AC85~264V (frequency: 47~63Hz) or DC110~370V	
Mechanical		
Size	140×35mm×100mm(H×W×D)(Excluding DIN rail)	
Installation method	35mm standard DIN rail installation	
Heat dissipation form	Aluminum alloy single-rib chassis surface heat dissipation, fanless	
IP protection	IP40	
Weight	About 0.44kg	
Working environment		

Operating temp.	-40 ~ +85°C
Storage temp.	-40 ~ +85°C
Humidity	5 ~ 95% (No condensation)
Industry standard	
EMC	IEC61000-4-2(ESD), Level4 IEC61000-4-5(Surge), Level4 IEC61000-4-4(EFT), Level4 IEC61000-4-3(RS), Level4 IEC61000-4-6(CS), Level4 ※The network port supports 6KV lightning protection

6 Order guide

Model	Gigabit SFP	Gigabit RJ45	Power supply
MIGE2206G-2GF-4GT	2	4	DC9-60V or AC85-264V (frequency: 47~63Hz) or DC110-370V optional
MIGE2208G-8GT	0	8	

7 Pledge

Thank you for purchasing Maiwe products. You will enjoy the following services when using Maiwe products.

We solemnly promises: under normal use, one month's return, one-year free maintenance, five-year warranty, and lifetime maintenance. The specific details are as follows:

- If Maiwe products have quality problems and cannot work normally, they

will be refunded for one month, free maintenance for one year, warranty for five years, and maintenance for life.

- If the number of repaired products is less than 10, the repair service will be completed within 7 days (excluding transportation time), and the repair service will be completed within one month for more than 10 sets.
- Optical passive products such as optical fibers, optical cables, jumpers, flanges, and optical cable terminal boxes are guaranteed within two years, but no return service is provided.
- The accessories and power supply that come with the product are guaranteed for one year.
- When sending the product back to Maiwe for repair, it is recommended that the customer use the original packaging or the packaging with the same protective effect, otherwise the customer shall bear the risks that occur during the transportation.
- The repaired product can enjoy another 6 months warranty service.
- The product after-sales service is detailed in the purchase and sale contract, and Maiwe has the final interpretation right of this description.

Wuhan Maiwe Communication Co., Ltd.

Add: Building E2, No. 2 Building, Area E, No. 52 Liufang Avenue, East lake

High-tech Development Zone, Wuhan, China.

Tel: 027-87170215/16 Fax: 027-87170217

Post Code: 430205

Site: www.maiwe.com

Statement

Due to the continuous updating and improvement of products and technologies, the contents of this manual will be updated from time to time. All the information in the manual is only used for instructions, if the content in the text does not completely match the actual product, please understand and please contact our customer service in time.

Copyright 2021 Maiwe Communication All rights reserved.

The right to interpret the information published in this material belongs to Wuhan Maiwe Communication Co., Ltd.